

# WASTEWATER TREATMENT AND SLUDGE DISPOSAL– WHAT ARE THE CHALLENGES?

H. Kroiss, M. Zessner\*

*\*Institute for Water Quality and Waste Management, Vienna University of  
Technology,  
Karlsplatz 13, A-1040 Vienna, Austria  
E-mail: hkroiss@iwag.tuwien.ac.at*

## INTRODUCTION

It is accepted worldwide that sustainable water protection can only be achieved by mechanical biological waste water treatment for all sewered settlements. According to the findings by Wuhrmann in the 50ies of the last century it is clear that the removal of oxygen consuming substances as carbonaceous pollution and ammonia from the waste water is a prerequisite or a very reliable precautionary principle in order to protect the development of the full food chain in rivers which corresponds to a good status of river quality. At the same time it was already clear that phosphorus is limiting the growth of algae and thus eutrophication in most of the deep lakes in moderate and cold climates. As a consequence waste water discharge has either to be avoided by adequate sewer systems or it needs phosphorus removal treatment before discharge. Two decades later it became obvious that the receiving marine estuaries or closed seas (Baltic, North Sea, Black Sea) suffer from eutrophication, too. Investigations showed that in many cases nitrogen is the limiting element for algae growth in the seas but also phosphorus can become limiting under special climatic conditions (summertime e.g.). As a consequence the nutrients became the decisive factors for the effluent standards in many European countries, especially for those discharging to sensitive receiving seas.

Already in the 60ies it was recognised that mechanical biological treatment (for the removal of carbonaceous pollution) does not solve the problem of receiving water pollution with recalcitrant compounds as heavy metals and the great variety of chemicals used in households trade and industry. All these substances could be detected in the sewage sludges and therefore also in the treated effluents. As a consequence source abatement for these potentially hazardous substances started by issuing strict effluent standards for these substances for industrial and trade effluents. This strategy of a combination of source abatement and end of pipe treatment is also the actual water protection strategy laid down in the European legislation (Framework Directive, Municipal Waste Water Directive, IPPC Directive). Furthermore it is state of the art to combine a strict precautionary principle with an environmental standard principle.

## SLUDGE PRODUCTION

The above mentioned water protection strategy forces all communities to treat their waste water by mechanical-biological (physico-chemical) processes which results in the production of sewage sludge. Sludge is not produced for any consumer but due to a legal requirement. This means that in any case there must be a reliable disposal method for the operator of the treatment plant. As a consequence it has to be considered that the beneficial use of the sludge in agriculture or for any other purpose has to be discussed taking into account both aspects:

- risk management regarding the use of the sludge (sustainability)
- risk management regarding of the disposal of the sludge (reliability)

The public has very well accepted the water protection strategy which has been very successfully applied during the last decades. The politicians like to demonstrate the positive effects of waste water treatment on receiving water quality but are much less “sensitive” in regard to the solution of sludge disposal because it is a controversial topic. It is commonly accepted that sewage sludge contains valuable compounds because this reminds us of the long tradition of nutrient recycling by waste water and manure application in agriculture over centuries, maybe millennia. The actual challenge in this respect is a completely different metabolism of the society which today is strongly influenced by material flows which did not exist in former centuries (fossil energy use, traffic, products from chemical and pharmaceutical industry, food industry, the use of heavy metals in building, cars etc.).

Common municipal waste water treatment processes result in the production of a dry mass of 7 to 50 kg/inhabitant and year if the sludge production of all dischargers to the municipal sewer systems (trade and industry effluents) are considered and related to the number of inhabitants served with the sewer system. 40 kgDS/inh./a is a typical value for the raw (not stabilised) sludge production of a larger community where the pollution load expressed as PE in the influent of the treatment plant normally corresponds to about twice the number of inhabitants. This mass can be reduced by sludge incineration to about 15 kg/inh./a. The lowest value of 7 kg/inh./a corresponds to the inorganic sludge fraction (i.e. remaining after sludge incineration) of the sludge of a small community where the pollution load in the waste water expressed as PE often corresponds to the number of inhabitants. If the sludge is applied in agriculture at least the inorganic fraction will remain little affected by the biological processes in the soil while the organic fraction will be degraded to a large extent.

## WASTE WATER COMPOUNDS AND THEIR SOURCES

The real challenge of waste water management is to optimise all the material flows and processes associated from the source until the final disposal. At the source the “pollution” is transferred to the (waste) water. The possible transfer of the waste water compounds to the air will be neglected. There are important storage and transformation processes along the transport from the sewer catchments to the treatment plant and finally at the treatment plant we have a transfer from one waste water flow to two different flows: treated effluent and sludge.

From the chemical equilibrium principle we have to assume that:

- the waste water contains all materials with which it gets into contact before discharge to the treatment plant
- all the materials contained in the treated effluent are also contained in the sludge and vice versa

When fresh water passes the atmosphere during precipitation it takes up all the compounds of the atmosphere, on the one hand all the compounds from the natural metabolic processes (gases, seeds, dust from erosion etc.) and the pollution caused by diffused global human activity in dissolved or particulate form on the other hand it can be specifically influenced by local emissions to the atmosphere. In the case of a combined sewer system this pollution can directly be transferred to the waste water, in the case of a separate sewer system directly to the

receiving water. All the soils are affected in any case by the diffuse atmospheric "pollution" either by deposition or by precipitation.

In this context it has to be mentioned that the introduction of lead free fuels resulted in a marked reduction of lead concentrations of the sludges of combined sewer systems. Another excellent example is the development of phosphorus free washing powders which lead to a reduction of the specific P-load in the waste water from about 4 to 1,7 gP/PE/d and strongly increased the cost efficiency of P-removal. These examples clearly show the possibilities to influence also on the "diffuse" pollution.

The tables 1 and 2 show data for two typical sources of heavy metals to municipal waste water in combined sewer systems.

**Table 1: Heavy metal discharge to the road runoff related to car travel distance**

Cadmium			Chromium			Copper			Nickel			Lead			Zinc		
mg/1000km *			mg/1000km *			mg/1000km *			mg/1000km *			Mg/1000km *					
min	max		min	max		min	Max		min	max		min	max		min	max	
0,24	0,24	5	3	30	3	40	150	3	250	250	1	170	170	5	200	520	3
2	5	3	20	40	2	160	160	1			5	110	370	3	600	1200	4

\* Reference: (1) Shaheen (1975) in Novotny (1995), (3) Muschak (1989), (4) approximation acc. Bannermann (1991) in Novotny (1995) (assumption: 7,5 - 15 m width of road, precipitation 1000 mm), (5) Lampert et al. (1997)

**Table 2:** Heavy metal discharge from roof runoff

	Cadmium		Copper		Lead		Zinc	
	mg/(m <sup>2</sup> .a)		mg/(m <sup>2</sup> .a)		mg/(m <sup>2</sup> .a)		mg/(m <sup>2</sup> .a)	
Reference	min	max	Min	max	min	max	min	max
(1) + (2)	0,006	0,4	40	170			550	1700
(3) + (4)	0,3	1,8	30	50	20	50	1300	2000

Reference: (1) + (2) Stark et al. (1995) und Lampert *et al.* (1997) - average assumption for Austria; (3) + (4) approximation based on Förster (1996) and (1998) - Bayreuth, Germany, city area, typical values (precipitation runoff: 600 - 900 mm /a)

During the infiltration of rain water into the soil the substances taken up from the atmosphere are retained and transformed by physical chemical and biochemical processes. The end products of these processes and the natural and anthropogenic soil compounds transported by the water will reach the ground water and finally enter our water supply systems and receiving waters. A fraction of the atmospheric pollution and of all the compounds of the soils in the catchments of the drinking water supply (protection) zones is contained in the drinking water. Also the materials used for the water distribution system lead to a diffused "pollution" of the water, which depends also on the chemical composition of the water and technological characteristics of the system. Water reaching the consumer is already a mixture of uncountable substances coming from natural and anthropogenic sources.

In this context it has to be mentioned that good (drinking) water quality cannot only be defined by the "absence" of chemical compounds but also by the presence of many elements (e.g. Ca, Mg). It is necessary to clearly distinguish between water composition and water quality.

Water composition is the result of the analytical tools we apply and the substances we select for analysis and for which we are able to measure the concentrations. The aim is a description of water composition often related to the use of the water. Quality depends on a decision on the bearable risk linked with the use of the water sometimes also the result of a cost/risk evaluation. This decision is based on scientific knowledge and experience but cannot completely be derived from analysis alone.

All the transfer processes of substances to the water mentioned above are influenced by specific local, regional and global conditions which cannot easily be influenced without strong political and economical backup. Even material flux changes can be achieved in regard to the diffused anthropogenic pollution, the possible effects in the environment will be very slow as they are linked to our present economic system. It is not clear for many of the compounds diffused all over the globe and in our environment by our activity whether they will cause a long term problem or can be included into the natural metabolism by adaptation or to which extent they can even enhance the evolution.

Natural metabolism “needs” diffuse pollution, e.g. the transport of minerals from the soil to the sea. The adaptation of the natural environment to changes in the material fluxes is driven by the quantity, the specific substances and the rate of the change. Natural evolution is characterised by long term slow changes and short term strong changes (high flow, volcanoes, droughts, etc.) the adaptation process often starts at the microbial level and cannot easily be detected and analysed. Most of the natural evolution is controlled by limiting substrates and complex communities, this makes it difficult to predict the effects of anthropogenic influence.

The water supplied to the consumers is the main transport medium for the end products of the human metabolism and for a variety of chemicals and waste products linked with our life style. There is a kind of competition between waste and waste water management in regard to the disposal of liquid and solid wastes.

The main constituents of the human metabolism are derived from the nutrition mainly organic carbonaceous matter, nutrients, trace elements and salts. These substances are mainly contained in urine and faeces (black water). The consumption of drugs for medical care results in their or their metabolic compounds' discharge to the black water. These substances are characterised by their effect on living systems even at very low concentrations. The fate and effect of these substances (pharmaceutical products, endocrine disruptors) to the waste water treatment and the aquatic environment is the subject of several international actual research programmes. Part of these substances may also be discharged via the skin and thus transferred to the grey water.

Other substances entering the waste water in the households come from personal care products, washing powders and products used for dish washing and cleaning purposes. They are contained in the grey water discharged to the sewer system.

From the point of view of the operator of a waste water treatment plant all the waste water constituents coming from the households have to be classified as diffused pollution, because there is nearly no possibility to directly influence on the sources. Many of the discharges from trade and industry can be characterised as point sources as their discharge can be controlled by discharge permits. During the last three decades great progress was achieved in reducing the potentially hazardous compounds coming from point sources. A strong precautionary principle based on the application of the best available technology to prevent or reduce pollution to the waste water has proved to be very efficient, at least in the industrialised

countries. It also turned out that such a precautionary principle is more efficient than a mere environmental standard principle. Investigations regarding the heavy metal concentrations in sewage sludge over the last decades show a tremendous decrease due to source abatement. There is also an indication that in many cases e.g. the heavy metal concentrations of sewage sludge coming from larger cities with marked influence of trade and industrial dischargers are lower than from treatment plants with only domestic waste water.

At the treatment plant itself the use of chemicals in most of the cases is restricted to metal salts for phosphorus removal and flocculants for thickening and dewatering the sludge (metal salts, organic flocculants, lime). If the source control of heavy metals is effective the heavy metal content of the metal salts (iron and alum salts) already markedly influences on the metal loads discharged to the treatment plant. The quality of the precipitants in regard to low heavy metal contents plays a decisive role today for sludge quality.

The following tables 3 and 4 show nutrient and recently reported heavy metal loads from references (in Zessner 1999):

**Table 3:** Contributions to the nutrient loads in domestic waste water per inhabitant (P)

Ref.	Faeces	Urine	Other pollution*	Cleaning agents**	Drinking water	Total
	g N/(P.d)	g N/(P.d)	g N/(P.d)	g N/(P.d)	g N/(P.d)	g N/(P.d)
[1]	9 – 11			0,3	0,3 - 0,9	10 - 12
[2]	9 - 10,5		3	0,3	0,2	12 - 14
[3]	0,9 - 2,8	9 - 11,5	3			13 - 18
[5]	1,8	12	-		-	14
[6]	1,7	3,4 - 12	-		-	5 - 14
[7]	1,2	11	1		-	13
[8]	1,5	11,5	-	-	-	13

Ref.	Faeces	Urine	Other pollution*	Cleaning agents**	Drinking water	Total
	g P/(P.d)	g P/(P.d)	g P/(P.d)	g P/(P.d)	g P/(P.d)	g P/(P.d)
[1]	1,4 - 1,8			0,2	0,0	1,6 - 2,0
[2]	1,3 - 1,8		0,1	0,2	0,0	1,6 - 2,1
[4]	0,3 - 0,8	0,8 - 2				
[5]	0,5	0,6 - 1,2	-		-	-
[7]	0,12	1,1	-		-	-
[8]	0,6	0,8	-	-	-	-

\* skin, remains from meals; \*\* washing powder, detergents for cleaning

Ref.: [1] (Kroiß *et al.*, 1997); [2] Lampert *et al.* (1997); [3] Pimparkar (1961), Buldau (1981), Jelinek (1939), Robinson (1954) and Widdowson (1960) zitiert bei Lampert *et al.* (1997) [4] Berger (1960), Consolatoio *et al.* (1963), Mitchell (1949) and Widdowson (1960) cited by Lampert *et al.* (1997) [5] Ciba-Geigy (1977) cited by Baccini, Brunner (1991) [6] Kraut (1981) cited by Baccini, Brunner (1991) [7] Laak R. (1980); [8] Pöpel F. (1973/96)

**Table 4:** Specific heavy metal loads in domestic waste water

Cd			Cr			Cu			Hg			Ni			Pb			Zn		
mg/(P.a)		*	g/(P.a)		*	g/(P.a)		*	mg/(P.a)		*	g/(P.a)		*	g/(P.a)		*	g/(P.a)		*
von	bis		von	bis		von	bis		von	bis		von	bis		von	bis		von	bis	
Domestic waste water (total)																				
15	15	14	0,20	0,20	11	2,7	3,6	15	16	33	9	0,20	0,20	11	0,60	0,60	7	13	14	13
30	30	7	0,08	0,28	10	4,0	4,0	8	50	50	11	0,15	0,60	10	0,60	0,60	13	8	16	10
50	50	15	0,40	0,40	7	4,0	4,0	11	67	67	5	0,80	0,80	3	0,70	0,70	11	11	17	15
200	200	4				8,0	8,0	4							3,50	3,50	4	33	33	6
200	200	5				11,3	11,3	5							7,50	7,50	5	37	37	5

Cd			Cr			Cu			Hg			Ni			Pb			Zn		
mg/(P.a)		*	g/(P.a)		*	g/(P.a)		*	mg/(P.a)		*	g/(P.a)		*	g/(P.a)		*	g/(P.a)		*
von	bis		von	bis		von	bis		von	bis		von	bis		von	bis		von	bis	
Faeces, urine,																				
9	9	16	0,01	0,02	10	0,6	0,7	10	2	2	16	0,07	0,09	10	0,02	0,02	16	3	4	15
10	10	15	0,02	0,02	3	0,9	0,9	5	2	4	3	0,09	0,09	3	0,01	0,03	10	4	4	5
Drinking water																				
8	10	15	0,01	0,01	5	0,5	1,0	15	0	1	5	0,03	0,14	10	0,14	0,14	15	1	1	10
9	15	5	0,02	0,08	10	0,9	1,5	5				0,20	0,40	5	0,09	0,15	5	4	6	5
Grey water (without drinking water „pollution”)																				
30	30	15	0,10	0,20	10	0,8	0,9	15	60	60	5	0,03	0,40	10	0,50	0,50	15	5	5	15
5	40	10	3,00	3,00	5	0,7	1,2	10				2,50	2,60	5	0,90	1,30	10	2	12	10

\* Lit.: (2) Röber, Höllwart (1981), (3) Bischofsberger, Ruf (1981), (4) ATV (1984) cited by Schönberger (1990), (5) Koppe, Klopp (1984), (6) ATV 2.3 (1982), (7) Batelle Institut e.V. (1984) cited by Schönberger (1990), (8) Nolte (1986)/Arpaci (1995), (9) Donner, Peschl (1986), (10) Moriyama K. et al., (1989), (11) Jenkins, Russell (1994), (12) Baccini et al. (1993), (13) Stark et al. (1995), (14) Boller (1997), (15) Lampert et al. (1997),

Interesting is the comparison of the data from the 1980ies, where the heavy metal loads are still much higher than today. During the last 5 years the changes of these loads are not any more relevant at least in Austria as they derive from the “diffused” sources only.

**Table 4:** Relative contribution of different sources of heavy metals to the overall load in domestic waste water:

	Cd	Cr	Cu	Hg	Ni	Pb	Zn
	%	%	%	%	%	%	%
Urine and faeces	25-33	1-2	22-31	13-15	5-35	3-6	27-38
Drinking water	19-27	3	19-58	1	13-15	15-29	13-27
Washing and cleaning	40-56	95-96	15-59	84-88	50-82	66-82	47-50

It turns out that the contribution of our nutrition and metabolism as well as the drinking water are important sources of Cd, Cu and Zn. In regard to nitrogen and phosphorus the main

sources are urine and faeces. Urine also contains most of the potassium load of the waste water. As a consequence recent research programs concentrate on separate collection and treatment of urine without dilution (Gujer) and on separate treatment of urine and faeces (Otterpohl) in order to be able to recycle N, P and K to agriculture with low or no dilution. Most of the pharmaceutical products for medical care are released to the environment via urine and/or faeces. Separate treatment of urine for the destruction of this pollution also seems to be more promising than in the highly diluted normal waste water.

## TRANSFORMATION AND TRANSFER OF POLLUTANTS DURING WASTE WATER TREATMENT

Depending on the sewer system the influent to the treatment plant mainly consists of the collected waste water from households, trade and industry at separate systems and it contains also part of the surface runoff from roads and roofs and the associated material fluxes when combined sewer systems are applied.

At the treatment plant we can distinguish transformation processes which mainly affect the organic pollution and the nutrients (especially nitrogen compounds) and the transfer of recalcitrant compounds to the different discharge products which mainly affects heavy metals and non biodegradable organic compounds. The end products of the waste water treatment process can be distributed to three compartments:

- effluent to the receiving water
- sludge to disposal after treatment
- atmosphere

The most important processes involved are:

- physical separation by sieving, sedimentation, flotation
- biological degradation of organic compounds
- biochemical oxidation of inorganic compounds (nitrification)
- chemical precipitation
- adsorption

Treatment efficiency in regard to water protection as well as for the transfer coefficients of the different waste water compounds is mainly determined by the biological treatment step.

The important basic relationships are:

- Monod (Michaelis-Menten) equation
- Solubility equilibria
- Adsorption isotherme (Langmuir)
- Mass balance

The first three relationships describe equilibria between the sludge and the effluent and are depending on the environmental conditions (e.g. temperature, pH, ORP) and operational parameters (e.g. sludge age, aerated volume, recirculation ratio). From these basic relationships it can be concluded that at steady state conditions the effluent concentrations are nearly independent of the influent concentrations:

The consequence is that with decreasing waste water flow (increasing influent concentrations) the percentage removal efficiency increases.

This should be the case for the removal of biodegradable COD, ammonia oxidation by nitrification phosphorus removal by chemical precipitation and heavy metals precipitation as hydroxides. In practice the situation is more complicated as waste water is a mixture of many compounds (and not a “pure” solution), a complex bacterial community is responsible for the

treatment and a real steady state does never exist. In regard to heavy metals it has to be considered that waste water contains complexing agents which inhibit precipitation.

The mass balance is mainly responsible for the denitrification efficiency and depends on the waste water composition and the process configuration. This is also the case for enhanced biological P-removal.

Table 5 shows the transfer coefficients for two small treatment plants in Austria, which have been investigated in detail over one year (Zessner 1999):

**Table 5:** Specific loads in the influent and their distribution to the different end products based on a mass balance over one year

TP	A ,2-stage ASP ("ts" ~25 d)				B, 1stage ASP (ts ~ 8d)			
	Influent + chemicals for Pprec.		sludge	effluent	influent		sludge	effluent
	g/PE/d	g/Inh/d	%	%	g/PE/d	g/Inh/d	%	%
CSB	110	224	28	7	110	92	43	12
N	8,2	16,7	17	18	1,5	1,3	15	67
P	1,05	2,1	86	14	12,5	10,5	26	74
	mg/PE/d	mg/Inh/ d	%	%	mg/PE/d	mg/Inh/d	%	%
Zn	59	120	51	46	127	106	45	53
Cu	17	34	77	19	15	12,6	56	42
Pb	2,5	5	72	16	3,9	3,2	79	16
Cd	0,13	0,27	53	44	0,19	0,16	38	59
Cr	3	6,1	80	18	3,4	2,9	49	46
Ni	2,5	5,1	68	30	2,9	2,4	34	62
Hg	0,03	0,06	> 46	< 52	0,14	0,11	(55)	(45)

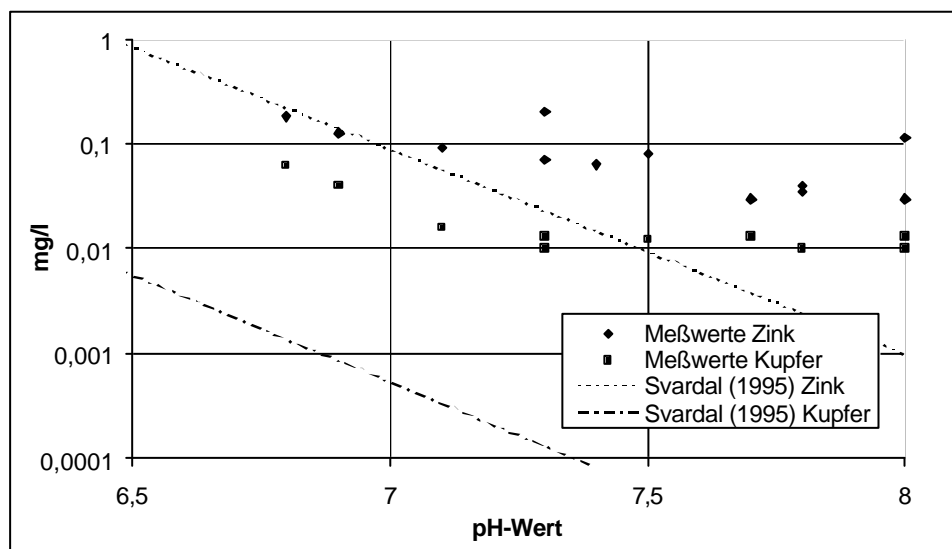

**Fig. 1:** Log heavy metal concentrations versus pH, theoretical equilibrium concentrations and full scale data at treatment plants A and B



As can be seen in Fig 1 the measured data for zinc and copper are higher than the calculated. This is especially significant for copper. It is assumed that complexing compounds play an important role for this effect as the deviation from the theoretical values increases with decreasing equilibrium concentrations.

Fig. 2 shows the material fluxes in treatment plant A as an example:



## Wagram West

Wassermengen, CSB, Stickstoff, Phosphor

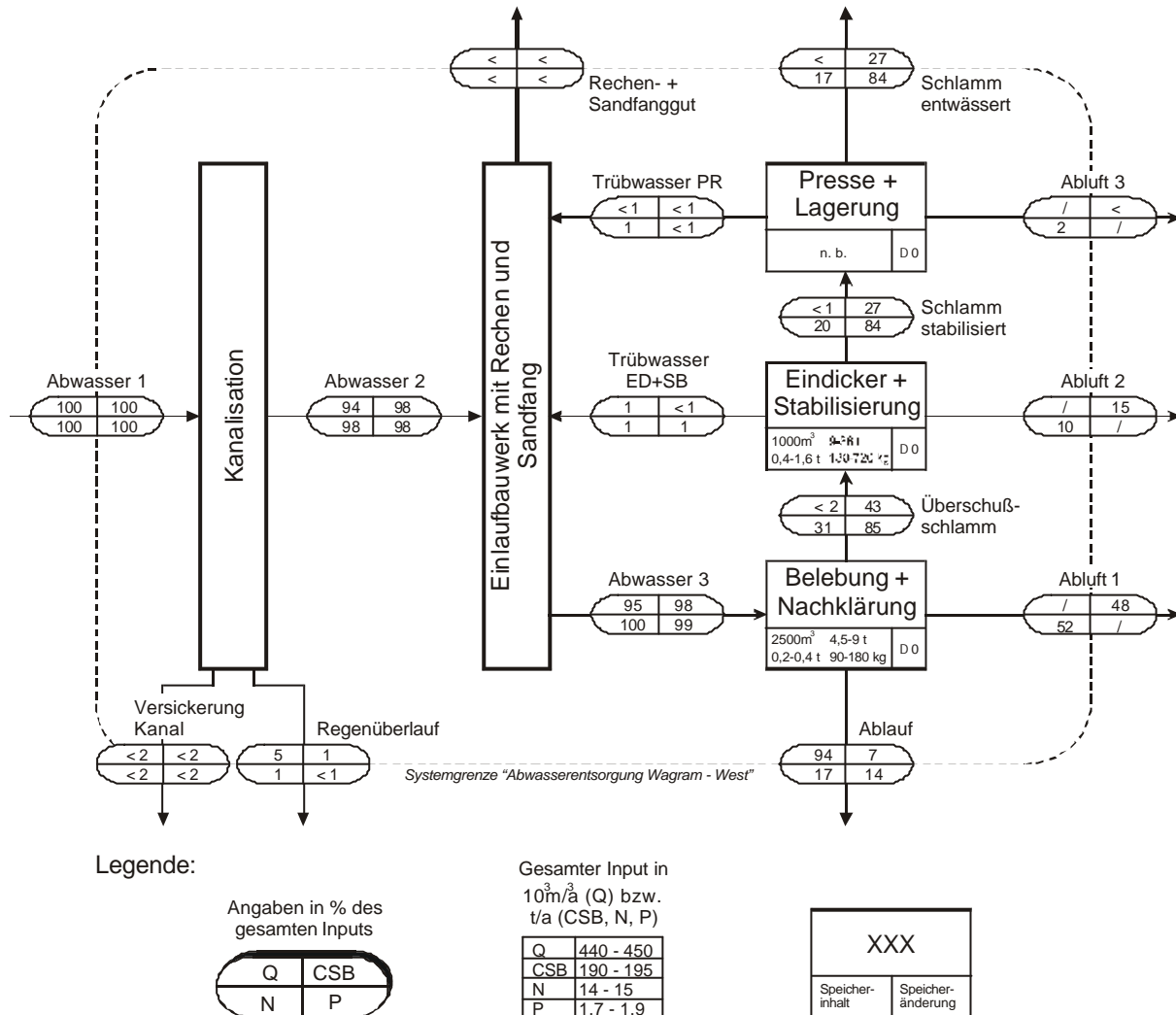

**Fig. 2:** Treatment plant A, mass balance for one year regarding flow, COD, N and P

### DISCUSSION AND CONCLUSIONS

Water protection by mechanical biological waste water treatment together with source control at the dischargers has proved to be very successful. From theoretical considerations and investigations in regard to the removal of hardly biodegradable substances (pharmaceuticals, endocrine disruptors, detergents etc.) from the waste water it can be concluded that effluent standards based on requirements for complete ammonia oxidation, N and P-removal also is in favour of the degradation of many of the potentially hazardous organic substances in the waste water and as a consequence in the sludge. A strong precautionary principle for source control at trade and industrial effluents discharged to the sewer systems is a very effective tool for the reduction of potentially hazardous compounds in the sludge and in the treated effluent.

The successful strategy for water protection results in sludge production. The quantity of sludge production is only little influenced by the treatment efficiency. This is not the case for sludge quality which also depends on waste water and sludge treatment technology.

Without a reliable disposal method (possibility) for the sludge the actual concept of water protection will fail. All the available alternative concepts do not change the material fluxes of recalcitrant substances, they only can result in different final disposal compartments.

Considering the compounds of sewage sludge the following statements can be made

:

- Waste water treatment results in a concentration of valuable and potentially hazardous compounds in the sludge
- The energy content of the waste water pollution is neglectable as compared to the actual energy consumption in the society but can be used for the reduction of the energy requirements of waste water treatment (e.g. anaerobic digestion)
- The calorific value of the water is much higher than the energy contained in the pollution and can be used for district heating (actually economically not competitive)
- Nitrogen is not a limited resource. The nitrogen contained in dewatered sludge is normally below 20% of the influent. Even without N-removal requirements this will not change very much. The greatest N-losses to the environment occur in agriculture. The contribution of agricultural use of stabilised sludge only little contributes to the N-turnover in agriculture. A marked contribution can be achieved by urine separation, treatment and application in agriculture.
- The organic material does not play any significant role as compared to the natural and anthropogenic metabolism. For recultivation purposes this can be interesting but the P-content is much too high and can result in important P-losses to the receiving waters.
- Phosphorus is a limited resource. Transfer of P from the waste water to the sludge is an economical process and results in a 85 to 90% recovery. Irrespective of the sludge treatment (land application, incineration) the phosphorus remains with the solids. Co-incineration leads to a dilution of the only valuable resource in the sludge and should be avoided. Separate disposal of the P containing residuals of sludge treatment should be considered for future recovery.
- Heavy metals contained in the sludge are not needed in agriculture because already the diffuse pollution by atmospheric outfall and precipitation is in the same order of magnitude as the withdrawal by the harvest. On the other hand they do not play any more a decisive role for soil protection as long as sludge application in agriculture is controlled according to the state of the art. Accumulation of heavy metals due to controlled agricultural use is extremely slow and can easily be monitored.
- The potentially hazardous compounds list can be prolonged at any time as the development and marketing of new substances by (chemical and pharmaceutical) industry will continue and part of these substances will find a way to the water system. At the same time analytical skills improve continuously and we will be able to detect more and more substances at lower and lower concentrations.
- The hygienic risk of agricultural use has become again the starting point of emotional discussions due to actual incidents (BSE, MKS). It is a new indicator that sludge application in agriculture may remain a non reliable disposal method for sewage sludge.

From these statements the following conclusions can be drawn :

- The real challenge is the risk management associated with sludge disposal. As this management has to include unknown risks it is not only a scientific question.
- The basis of the risk management for the known risks are thorough scientific investigations in the pathways of the compounds, Mass balances are one of the important tools for quality control.
- The only compounds which can reliably be prevented from the waste water and the sludge are those which are not produced.
- The management of material flows is a complex problem and needs a co-operation of all parties involved, there are successful examples in the history.
- Risk management has to consider the economical implications of risk reduction processes.
- Risk management has to consider the risks of human health and sustainable environmental conditions by sludge disposal but also the risk of unsatisfactory waste water treatment due to endangered sludge disposal possibilities. (especially caused by unforeseeable media actions and often as a consequence by new legal restrictions)
- A limited number of reliable technical and organisational sludge disposal methods have been developed (agricultural use , incineration with land fill disposal)
- New alternative solutions regarding waste water transport and treatment will not solve most of the problems associated with risk management.
- Sustainability and reliability are not always in accordance – this is a challenge, too.

#### LITERATURE:

- M. Zessner (1999): Bedeutung und Steuerung von Nährstoff und Schwermetallflüssen des Abwassers (Doctoral thesis: Importance and control of nutrient and heavy metal fluxes in waste water systems). Wiener Mitteilungen. Band 157. TU- Wien, Institut für Wassergüte und Abfallwirtschaft. Hsg. H. Kroiss